

INQUIRY FORM

for the purpose of quotations and production

Contact details

Company		Email	
Contact person		Phone	
Address			

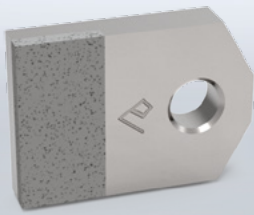

NEEDLE TILE

- > Single-profile dressing of straight and even grinding wheel surfaces
- > Fast dressing without scoring
- > Rough dressing
- > Correction of imbalances

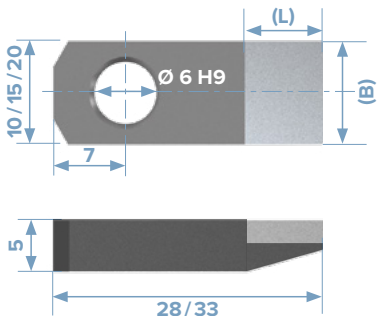
Quantity		Tile total length	<input type="checkbox"/> 28 mm	<input type="checkbox"/> 33 mm
		Tile plate (B x L)		
		<input type="checkbox"/> 10 mm x 10 mm	<input type="checkbox"/> 10 mm x 15 mm	<input type="checkbox"/> 10 mm x 20 mm
		<input type="checkbox"/> 15 mm x 10 mm	<input type="checkbox"/> 15 mm x 15 mm	<input type="checkbox"/> 15 mm x 20 mm
		<input type="checkbox"/> 20 mm x 10 mm	<input type="checkbox"/> 20 mm x 15 mm	

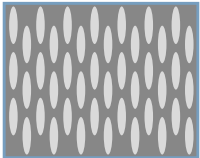
Diamond needles (Natural diamonds)		<input type="checkbox"/> DFN 1,4/SPC 50	SPC = stones per carat
		<input type="checkbox"/> DFN 1,8/SPC 30	
		<input type="checkbox"/> DFN 2,5/SPC 20	

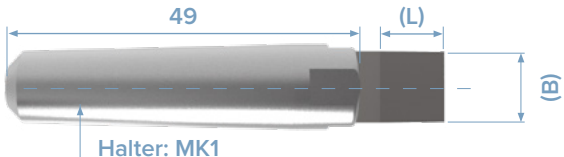
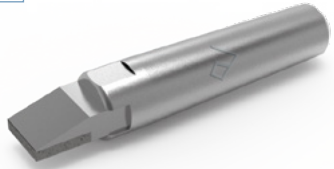
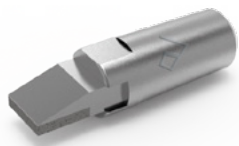
Quantity/Holder	<input type="checkbox"/> MK1	<input type="checkbox"/> MK1 short
		

Abrasive grit	<input type="checkbox"/> Corundum	<input type="checkbox"/> Silicon carbide	<input type="checkbox"/> Other	Ø in mm	Width in mm	
Profile	<input type="checkbox"/> Yes	<input type="checkbox"/> No	Graining	Cooling	<input type="checkbox"/> Yes <input type="checkbox"/> No	<input type="checkbox"/> Emulsion <input type="checkbox"/> Oil
Description of the dressing procedure/process						

You have not found the right tool for your application? Please do not hesitate to contact us.